

DZ45X-16Q

FLANGE END RESILIENT SEAT NON-RISING STEM GATE VALVE

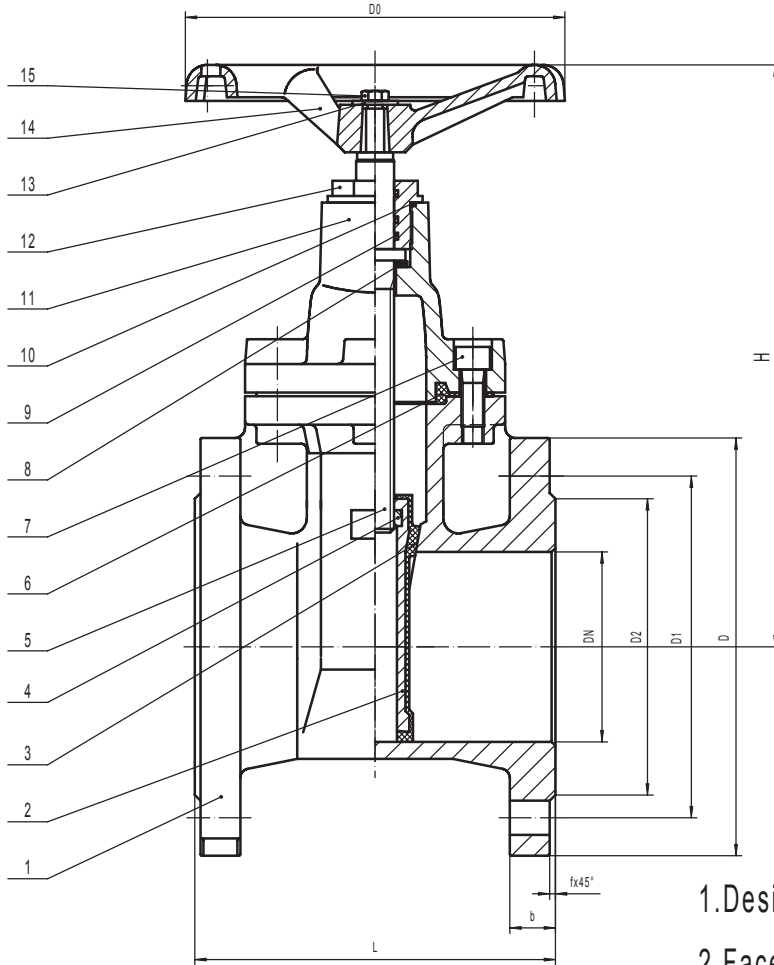

Scope of application

Nominal pressure		1.6MPa
suitable medium		water
test pressure	shell	2.4MPa
	seat	1.76MPa
test time	DN50-150	60s
	DN>150	120s
temperature		≤80°C

Technical requirement

- 1.Design,manufacture conforms to DIN 3352.
- 2.Face to face dimension conform to Series 14 of BS EN 558-1.
- 3.Flange drilled conforms to BS EN1092.

DN	L	D	D1	D2	b	f	n-d	Do	15	14	13	12	11	10	9	8	7	6	5	4	3	2	1	
40	140	150	110	84	18	3	4-19	160	bolt	handwheel	washer	stuffing box	bonnet	O-ring	O-ring	gasket	screws	flange gasket	stem	stem nut	wedge	wedge frame	body	
50	150	165	125	102	19	3	4-19	160	steel	ductile iron	steel	cast brass	ductile iron	NBR	NBR	Teflon	steel	NBR	stainless steel	cast brass	NBR	ductile iron	ductile iron	
65	170	185	145	122	19	3	4-19	160	DIN17100 RSt37-2	DIN1693 GGG50	DIN17100 RSt37-2	DIN17656 G-CuZn37Pb	DIN1693 GGG50				DIN C30		DIN17440 X20Cr13	DIN17656 G-CuZn37Pb		DIN1693 GGG50	DIN1693 GGG50	
80	180	200	160	132	19	3	8-19	200	GB700-88 Q235	GB1348-88 QT500-7	GB700-88 Q235	GB1176-87 ZCuZn40Pb2	GB1348-88 QT500-7	NBR	NBR	HG/T2902	GB699-88 30	NBR	GB1220-92 2Cr13	GB1176-87 ZCuZn40Pb2	GB1176-87 ZCuZn40Pb2	GB1348-88 QT500-7	GB1348-88 QT500-7	
100	190	220	180	156	19	3	8-19	200																
125	200	250	210	184	19	3	8-19	250																
150	210	285	240	211	19	3	8-23	320																
200	230	340	295	266	20	3	12-23	320																
250	250	405	355	319	22	3	12-28	320																
300	270	460	410	370	24.5	4	12-28	360																
350	290	520	470	429	26.5	4	16-28																	
400	310	580	525	480	28	4	16-31																	
450	330	640	585	548	30	4	20-31																	
500	350	715	650	609	31.5	4	20-34																	
600	390	840	770	720	36	5	20-37																	
NO.	Name of part		material	Germany standard	Chinese standard																			